

1
GT200 FOUNDATION
SCALE: NTS

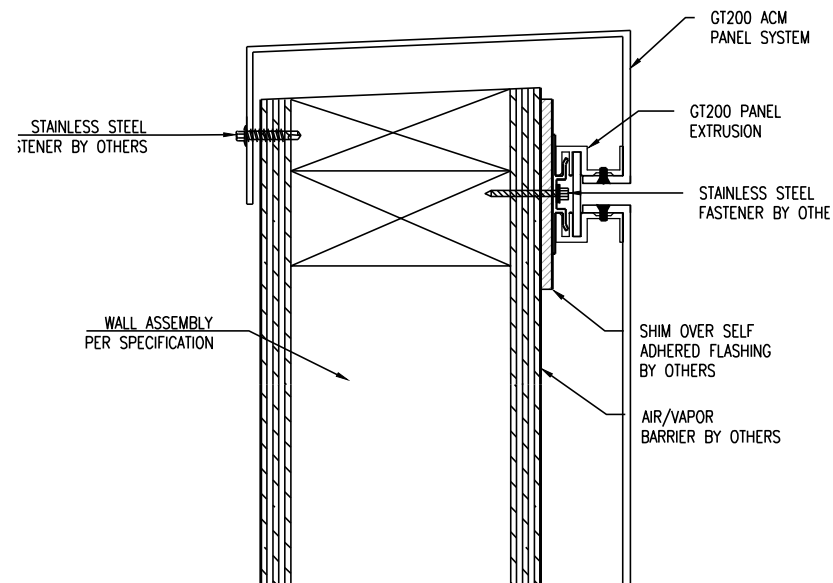

2
GT200 ACM COPING
SCALE: NTS

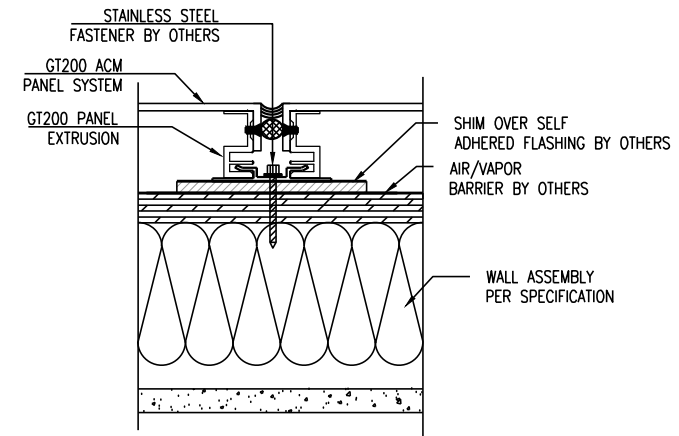

3
GT200 COPING PANEL JOINT
SCALE: NTS

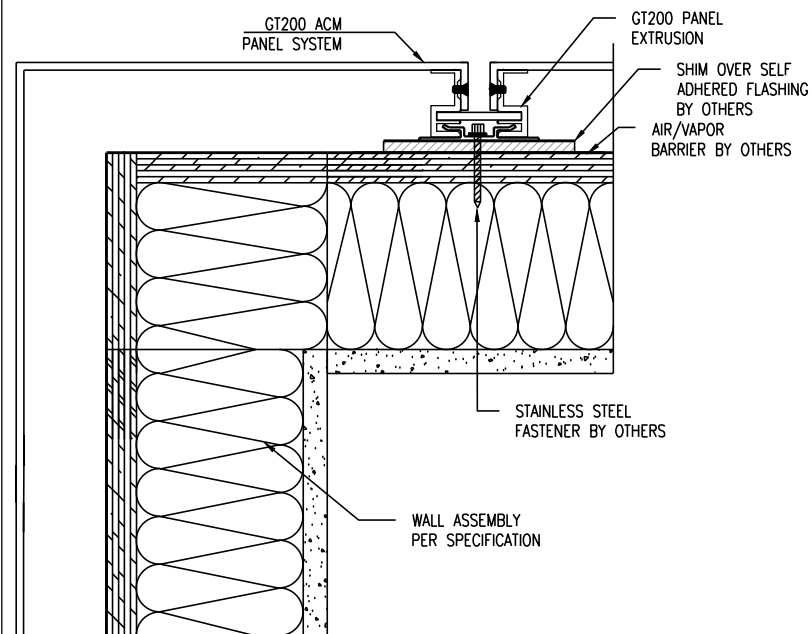

4
GT200 OUTSIDE CORNER
SCALE: NTS

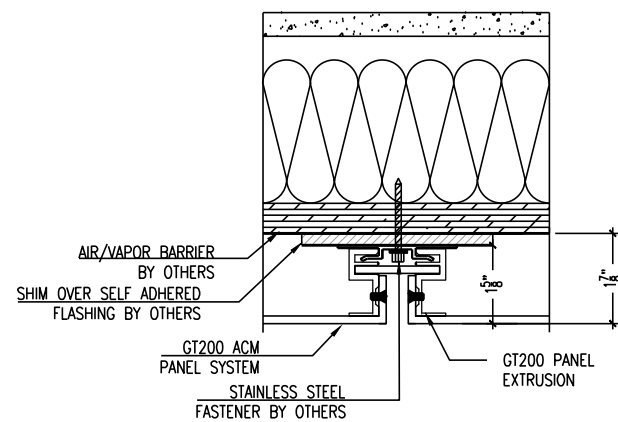

5
GT200 VERT. JOINT DETAIL
SCALE: NTS

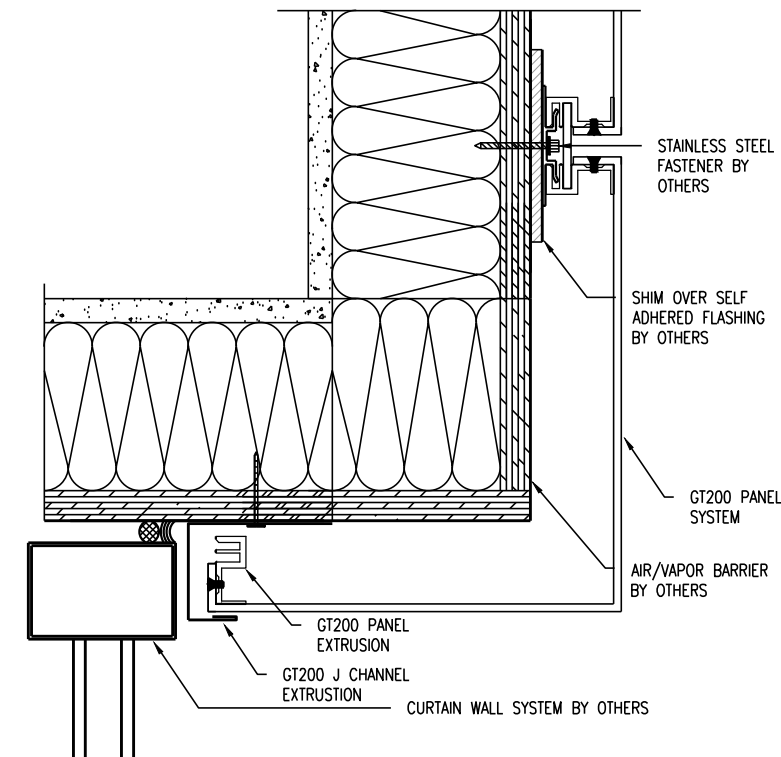

6
GT200 SOFFIT DETAIL
SCALE: NTS

NOTES:

1. CONTRACTOR TO FIELD VERIFY DIMENSIONS.
2. THESE DRAWINGS REPRESENT CONTRACTOR'S INTERPRETATION OF THE BIDDING ARCHITECTURAL DRAWINGS & SPECIFICATIONS.
3. CHANGES TO THE ORIGINAL ARCHITECTURAL DRAWINGS OR CHANGES TO THE ERECTION OF THE BUILDING COULD RESULT IN REQUIRED COMPENSATION FOR CHANGES.
4. OIL CANNING IS NOT A CAUSE FOR REJECTION.
- 5.

CONTRACT DATE:
 SUBMITTAL DATE:
 RETURN DATE:
 REVISION DATE:

CONTRACTOR PROJECT #:

PROJECT:
 ARCHITECT:
 GENERAL CONTRACTOR:

OWNER:
 LOCATION: