

1
310 FOUNDATION
SCALE: NTS

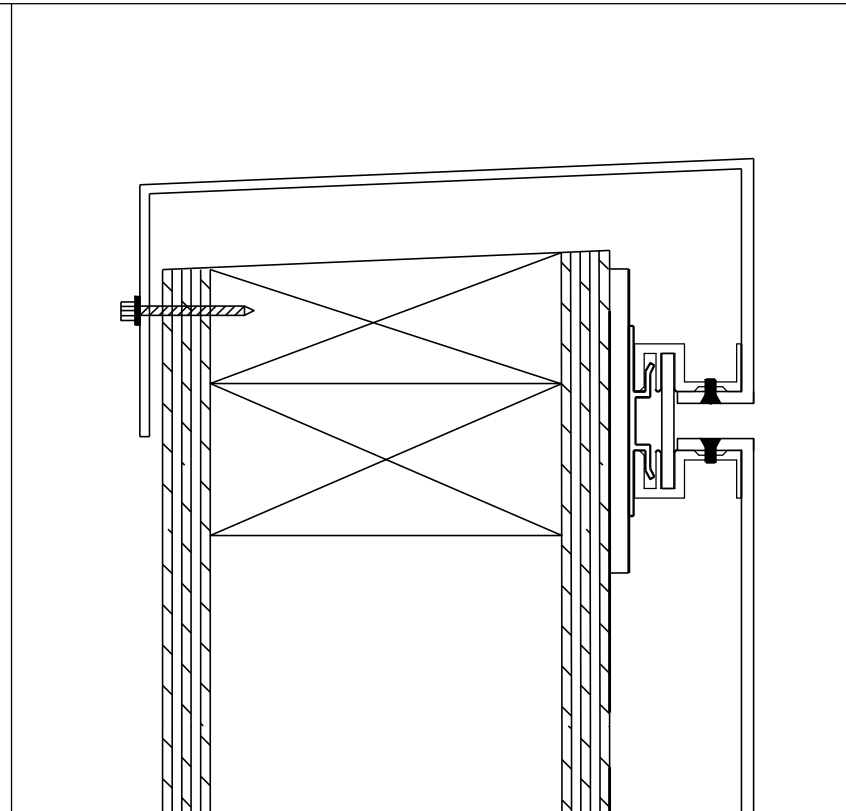

2
310 ACM COPING
SCALE: NTS

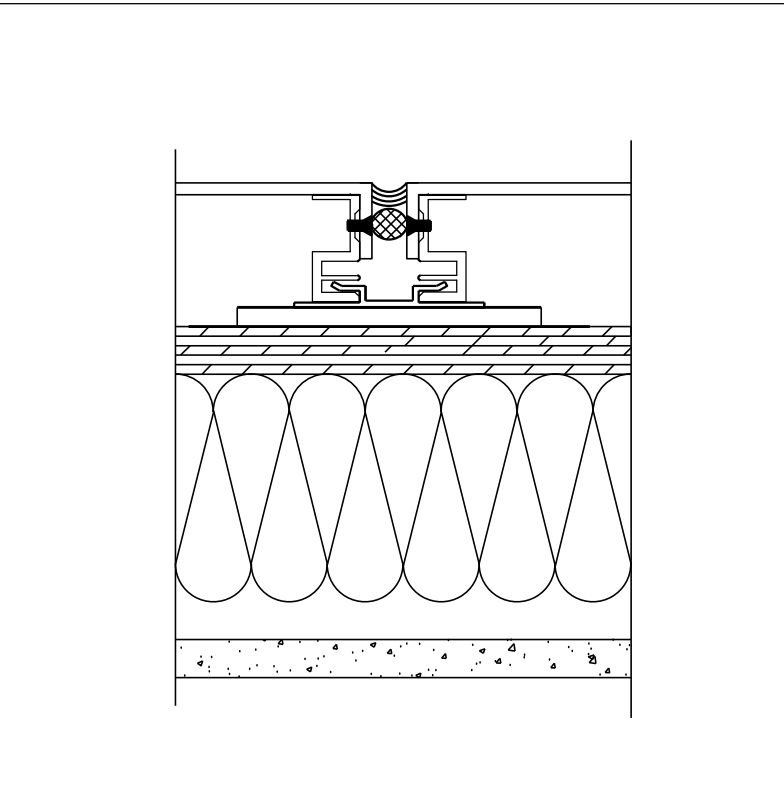

3
310 COPING PANEL JOINT
SCALE: NTS

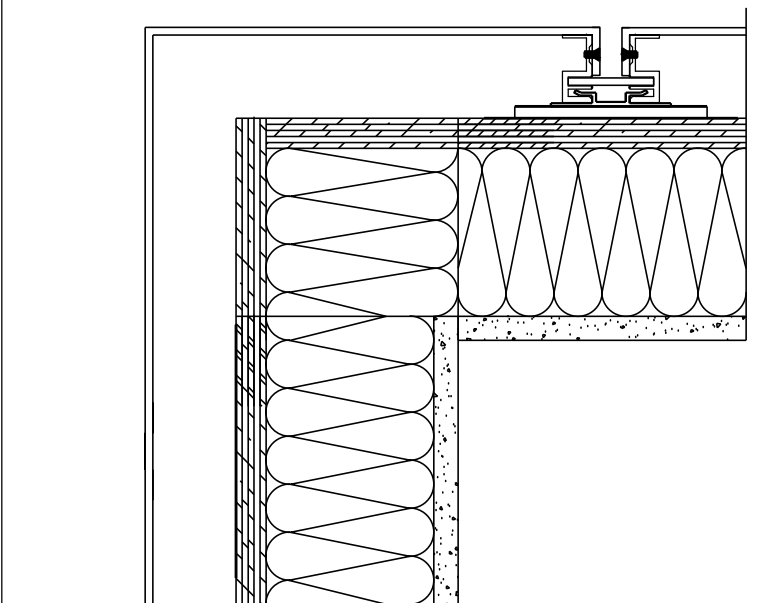

4
310 OUTSIDE CORNER
SCALE: NTS

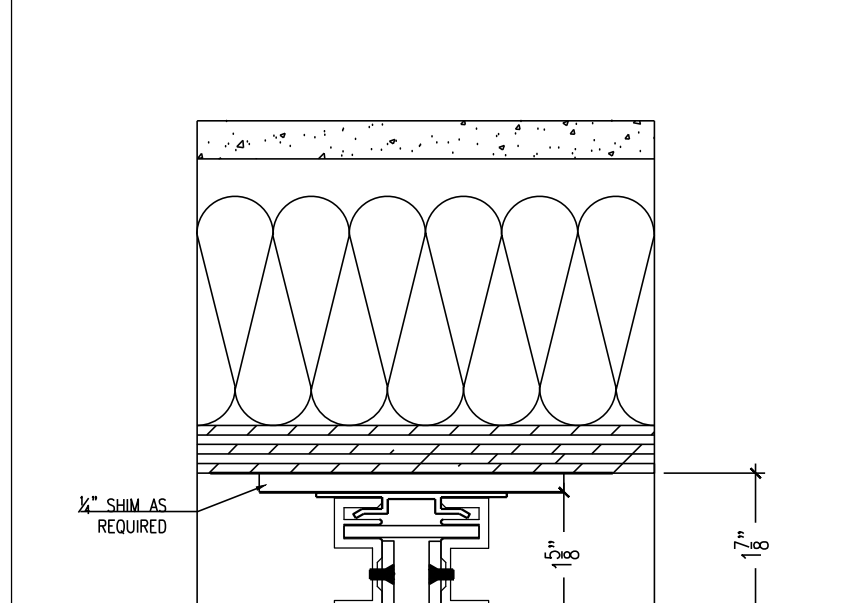

5
310 VERT. JOINT DETAIL
SCALE: NTS

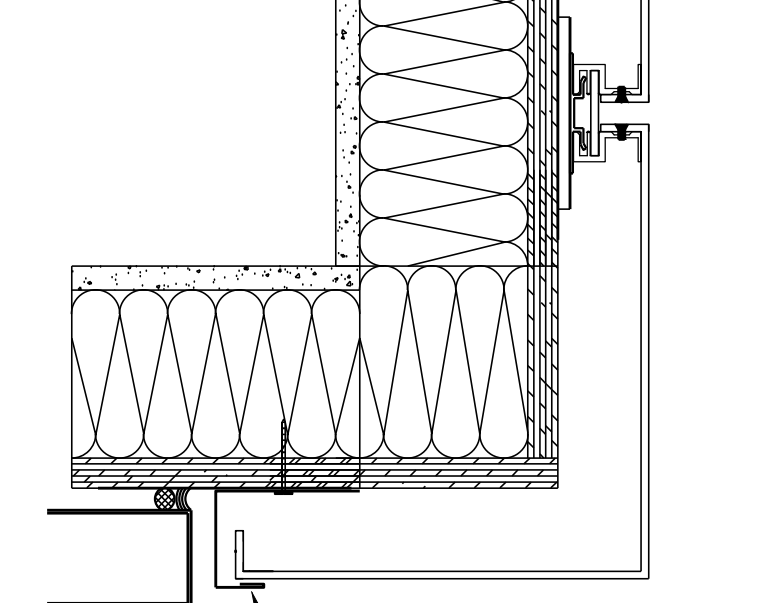

6
310 SOFFIT DETAIL
SCALE: NTS

- NOTES:
1. CONTRACTOR TO FIELD VERIFY DIMENSIONS.
 2. THESE DRAWINGS REPRESENT CONTRACTOR'S INTERPRETATION OF THE BIDDING ARCHITECTURAL DRAWINGS & SPECIFICATIONS.
 3. CHANGES TO THE ORIGINAL ARCHITECTURAL DRAWINGS OR CHANGES TO THE ERECTION OF THE BUILDING COULD RESULT IN REQUIRED COMPENSATION FOR CHANGES.
 4. OIL CANNING IS NOT A CAUSE FOR REJECTION.
 - 5.

CONTRACT DATE:
 SUBMITTAL DATE:
 RETURN DATE:
 REVISION DATE:

CONTRACTOR PROJECT #:

PROJECT:
 ARCHITECT:
 GENERAL CONTRACTOR:

OWNER:
 LOCATION:

INDEX:	
100	COVER SHEET
101	ROOF PLAN
120	REFLECTIVE CEILING PLAN
200's	ELEVATIONS
300's	DETAILS
400's	PRODUCT DATA